

AR 400E4-L SILEO AXIAL FAN

Item no. 34467

Document type: **Product card**

Document date: **2016-06-23**

Generated by: **Systemair Online Catalogue**

Description

- speed controllable by voltage reduction
- inlet protection guard
- safe and maintenance free operation
- can be installed in any mounting position
- electric connection via terminal box mounted on the casing
- supplied with capacitor

Axial fans of the AR sileo range do have a bionic shape of the fan blade, and are driven by external rotor motors. The AR range is mounted in a round casing according Eurovent 1/2, galvanized steel and powder coated in black (RAL9005). The axial impeller is manufactured from black high efficiency composite material. The impeller is balanced dynamically in two levels in accordance with DIN ISO 1940 part 1, quality G6.3.

The motors are equipped with thermal contacts for motor protection, with leads to be connected to a motor protection unit, for example Systemair unit S-ET.



Technical parameters

Voltage	230	V
Frequency	50	Hz
Phase	1	~
Input power (P1)	260	W
Current	1,15	A
Max. airflow	1226	l/s
R.p.m.	1320	r.p.m.
Max. temperature of transported air	55	°C
Max. temperature of transported air when speed-controlled	55	°C
Sound pressure level at 1 m	66	dB(A)
Weight	10,1	kg
Insulation class	F	
Enclosure class, motor	54	IP
Capacitor	5	µF

Diagrams

Diagrams

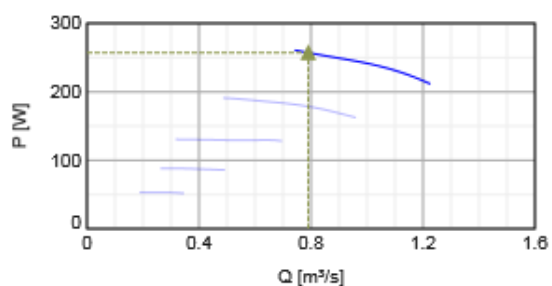
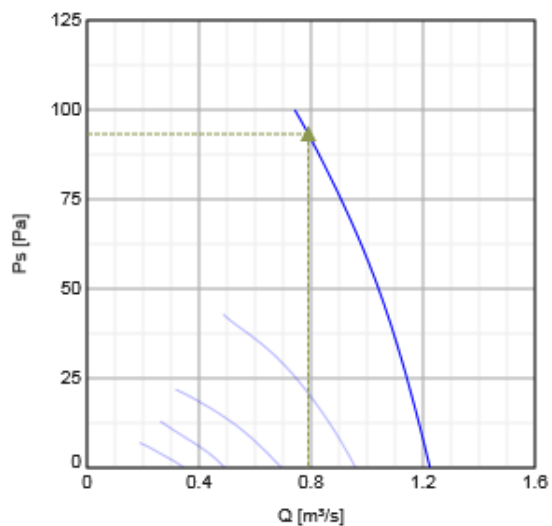

Hydraulic data

	Working point						
	Q [m³/s]	Ps [Pa]	P [W]	n [r.p.m.]	I [A]	SFP [kW/m³/s]	U [V]
Max efficiency	▲ 0,79	▲ 93,3	▲ 257	1322	1,13	0,326	230

Acoustic data

Sound power level	63	125	250	500	1k	2k	4k	8k	Tot
Inlet									
Outlet									

Dimensions

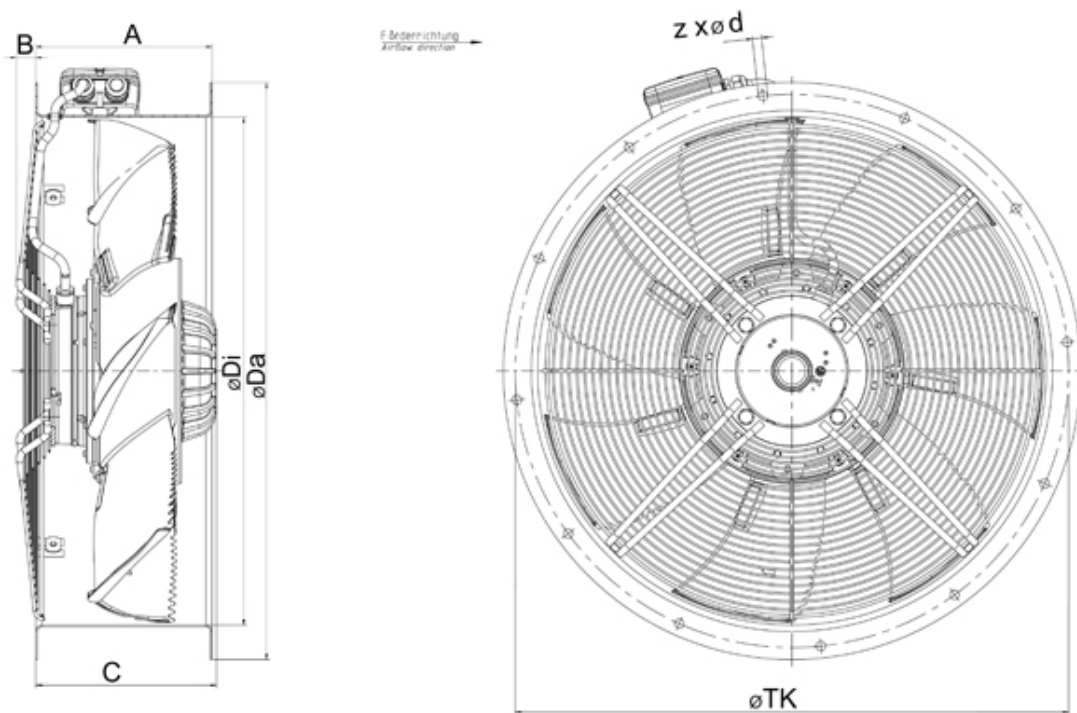

	A	B	C	ØDi	ØDa	z x Ød	ØTK
AR 400E4 sileo	155	16	138	400	480	8 x Ø12	450
AR 400DV sileo	155	16	138	400	480	8 x Ø12	450

Wiring

Linkslauf
Counter Clockwise rotation
Rotation à gauche

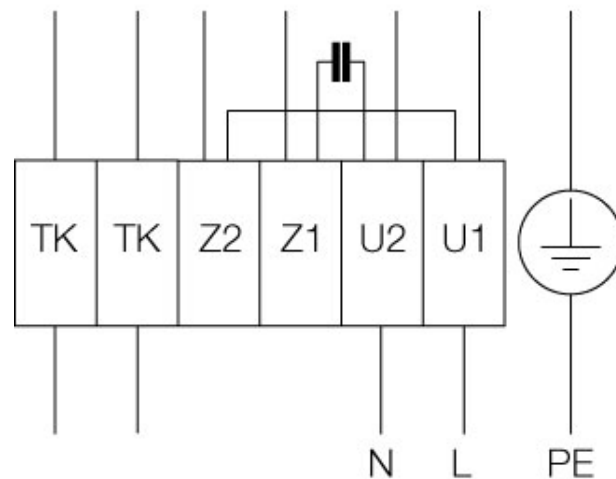

Accessories

Electric accessories

- REV-5POL/05 ON/OFF (33979)
- REE 2 Speed control (5316)
- S-ET 10 Motor Protection (5154)
- AWE-SK Motorprotection 2A/230V (5138)
- RTRE 1,5 Speed control (5008)
- REU 1.5 Speed control (5004)
- STL 1.5 Speed controller (84251)

Accessories

GFL-AR/AXC 400 counter flange (8378)

Documentation

 2015-01_EC-declaration of conformity Axial_DE-EN.pdf (100,49kB)

 Operating and maintenance instructions_2010-07.pdf.pdf (488,24kB)

 BAL-axial-sileo-Systemair-08-2013.pdf (244,69kB)

Specification text